

## OPTI saw® S 275N / S 275NV

### Metal band saw with pivoting saw head.

S 275NV with continuously adjustable saw band speed

#### Facts that impress in terms of quality, performance and price

- ▶ Low-noise running action
- ▶ Rugged cast design
- ▶ Excellent cutting precision thanks to vibration-free action
- ▶ Saw band lowering via hydraulic cylinder continuously adjustable by throttle valve
- ▶ Microswitch for automatic limit position cut-off
- ▶ Coolant system
- ▶ Equipped as a factory standard with bi-metal saw blade
- ▶ Adjustable material stop for batch work
- ▶ Rugged machine chassis
- ▶ Ball-bearing borne saw band guide
- ▶ Quick clamping vice, adjustable via hand wheel. Workpiece is clamped using a handy quick-clamping lever
- ▶ Easily legible scale for adjusting the angle
- ▶ Overload protection

**S 275N**  
 ▶ Motor circuit switch  
 ▶ Two switchable speeds

**S 275NV**  
 ▶ Saw band speed continuously adjustable from 20 to 90 m/min.  
 ▶ Speed change possible during operation

#### Pressure gauge

- › Easy and accurate adjustment of the saw band tension



Fig.: S 275N



#### Dimensions

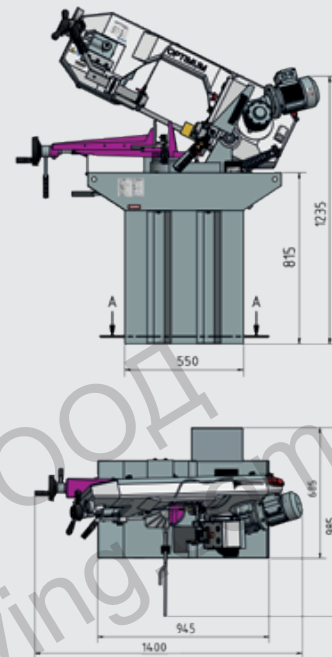

#### Scope of supply

- › Material stop
- › Bi-metal saw band
- › Machine chassis
- › Coolant pump

#### Cutting areas

0°	Ø 225 mm	170 mm	150 x 245 mm
45°	Ø 145 mm	145 mm	145 x 180 mm
60°	Ø 90 mm	90 mm	90 x 120 mm

The cutting area was determined for a full section.  
 The cutting range can be larger in case of cut-off sections.

Model	S 275N	S 275NV
Article no.	3300260	3300265

Technical specifications		
Electrical connection	400 V / 3 Ph ~50 Hz	230 V / 1 Ph ~50 Hz
Motor output	1.1 kW	1.5 kW
Coolant pump motor	90 W	
General instructions		
Lifting the saw head	manual	
Feed	continuously variable	
Saw band speed	45 / 90 m/min	20 - 90 m/min
Saw band dimensions	2 480 x 27 x 0.9 mm	
Cutting angle	0° to 60°	
Dimensions		
Length	1 400 mm	
Width without/with material stop	685 mm / 985 mm	
Height bottom/top limit position	1 235 mm / 1 700 mm	
Weight	185 kg	

AQUACUT C1	3530030
------------	---------

- › For cooling the cut
- › 10 litres

#### Saw bands HSS bi-metal M 42

Teeth per inch	Tooth angle	Art.no.
5 - 8 tpi	0°	3357511
5 - 8 tpi	6°	3357512
6 - 10 tpi	0°	3357524
6 - 10 tpi	6°	3357510
10 - 14 tpi	0°	3357525

Saw band set HSS bi-metal M 42		
1 pc. Saw band 6 - 10 tpi; 6°		3357504
1 pc. Saw band 5 - 8 tpi; 0°		
1 pc. Saw band 5 - 8 tpi; 6°		

„General saw band information“ on page 220